



world
class
winches

Hydraulic Planetary Gear Winches

H150PF

Pneumatic freespool clutch Type No 63.34-001

15 TONNES WINCH



Pulling force

	Metric std.	US std. (approx.)
- bottom rope layer	15.0 tonnes	33 700 Lbs
- top rope layer	11.0 tonnes	24 700 Lbs

Rope speed in low auto 2-speed

	Metric std.	US std. (approx.)
- bottom rope layer	5.0 m/min	16 ft/min
- top rope layer	7.0 m/min	23 ft/min

Rope speed in high auto 2-speed

	Metric std.	US std. (approx.)
- bottom rope layer	13.0 m/min	43 ft/min
- top rope layer	18.0 m/min	59 ft/min

Max oil pressure

175 bar 2500 psi

Max oil flow

70 l/min 18 gal/min

Drum diameter

266 mm 10.47 inch

Rope diameter

19 mm 0.75 inch

(Acc. to DIN 14584, MBL ≥ 295 kN)

Rope length

60 m 197 ft

Numbers of layers

4 4

Winch weight

370 kg 815 Lbs

Rope weight

106 kg 234 Lbs

Dimensional drawing (dimensions in mm)

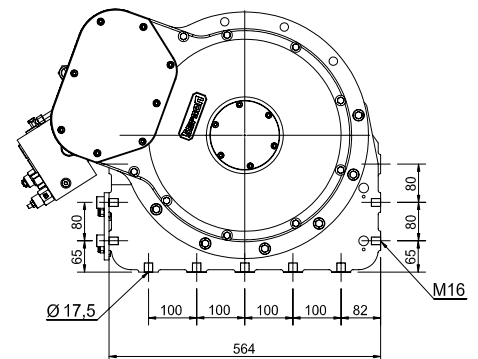
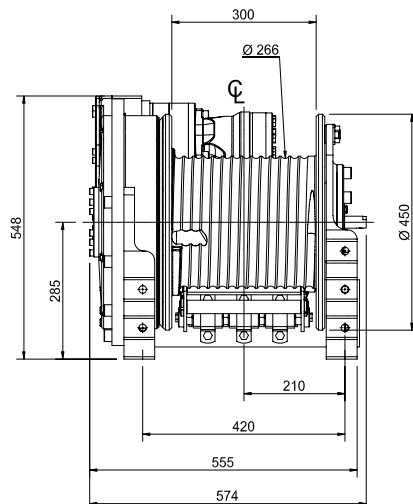

SEPSON AB
SE-780 50 Vansbro
Sweden
Tel +46 281 758 40
Fax +46 281 710 09
info@sepson.se
www.sepson.com

Pulling force over the rope length

	Pulling force (tonnes)	Rope speed (m/min)	Total Rope on the drum (m)
1st	15,0	5,0	13,5
2nd	13,2	5,5	28,7
3rd	11,8	6,5	45,8
4th	11,0	7,0	64,6

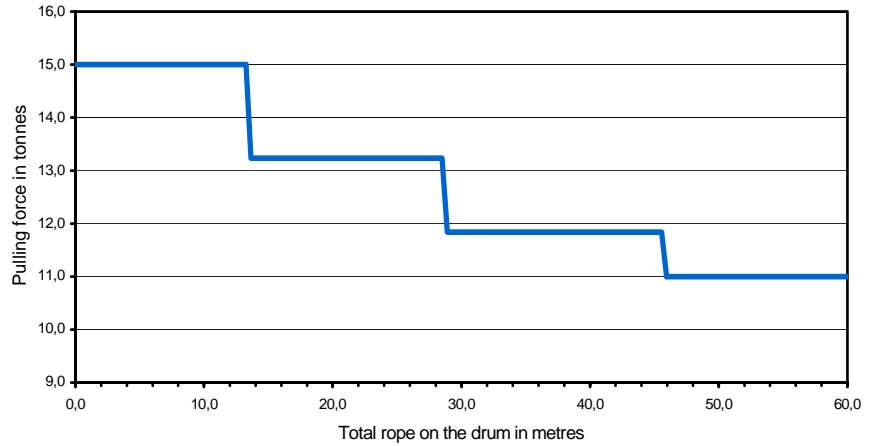

Mounting instructions

The winch should be mounted on a 20 mm steel mounting plate fixed to the vehicle.

The winch must be fitted to the mounting plate with 12 bolts M16 (hot galvanized) quality 12.9.

Tightening torque 210 Nm (21 kpm) when oiled.

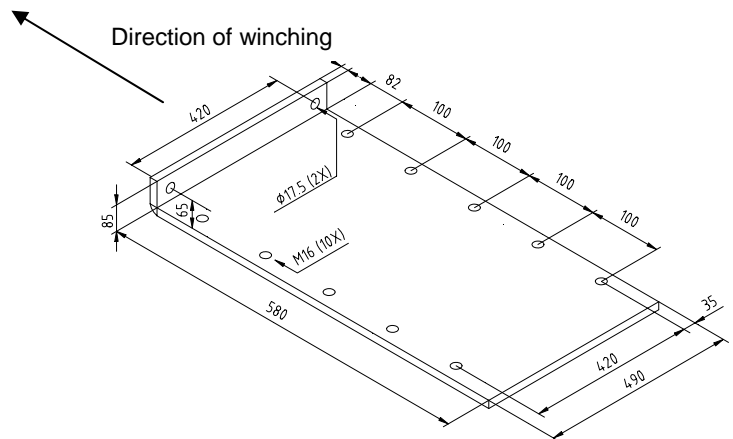

Hydraulic installation

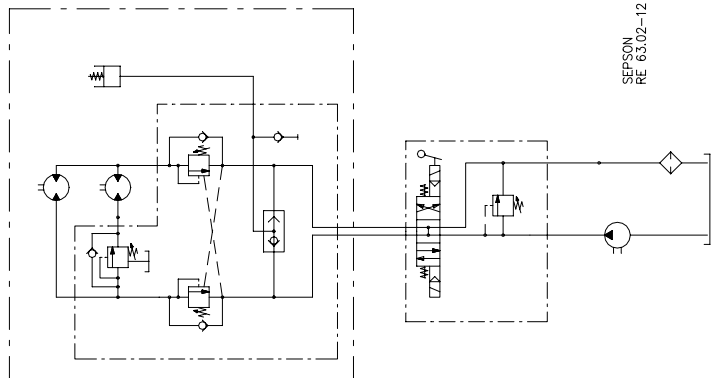
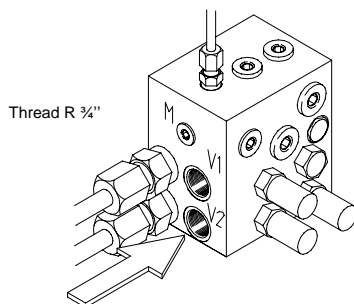

SEPSON
RE 63.02-12

Declaration of Conformity

According to the Machine Directive 98/37/EC, Annex IIA

Sepson AB, P.O. Box 172, SE-780 50 Vansbro, Sweden declare under our sole responsibility that:

The winch type 63.34 with serial numbers 100-600

- are manufactured according to the Machine Directive 98/37/EC
- are manufactured according to following harmonized standards – EN 292-1 and 2