



world  
class  
winches

# Hydraulic Planetary Gear Winches

## H100PS

Pneumatic freespool clutch Type No 63.31-014

### 10 TONNES WINCH FOR SIDE MOUNTING



#### Pulling force

	Metric std.	US std. (approx.)
- bottom rope layer	10.0 tonnes	22 500 Lbs
- top rope layer	6.5 tonnes	14 600 Lbs

#### Rope speed

	Metric std.	US std. (approx.)
- bottom rope layer	6.0 m/min	20 ft/min
- top rope layer	9.5 m/min	31 ft/min

#### Rope speed in high auto 2-speed

	Metric std.	US std. (approx.)
- bottom rope layer	n/a	n/a
- top rope layer	n/a	n/a

#### Max oil pressure

160 bar 2300 psi

#### Max oil flow

60 l/min 16 gal/min

#### Drum diameter

224 mm 8.82 inch

#### Rope diameter

16 mm 0.63 inch

(Acc. to DIN 14584, MBL ≥ 197 kN)

#### Rope length

60 m 197 ft

#### Numbers of layers

5 5

#### Winch weight

210 kg 472 Lbs

#### Rope weight

67 kg 151 Lbs

### Dimensional drawing (dimensions in mm)

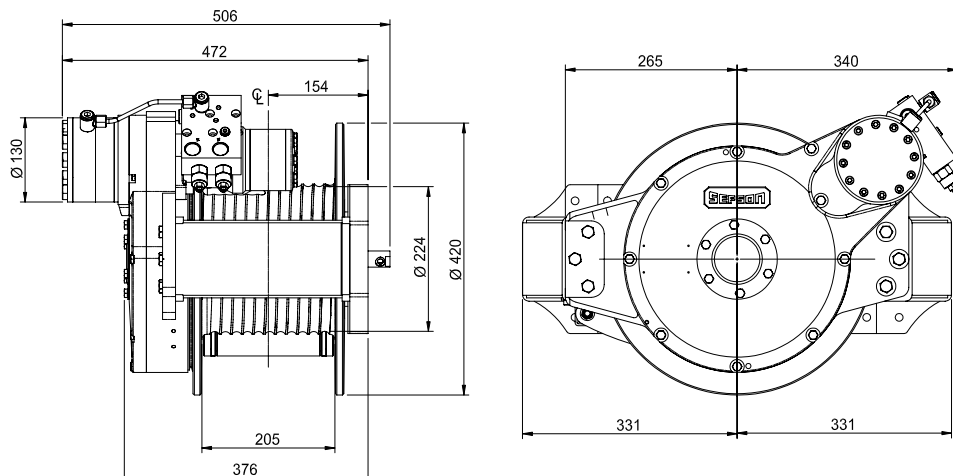

SEPSON AB  
SE-780 50 Vansbro  
Sweden  
Tel +46 281 758 40  
Fax +46 281 710 09  
info@sepson.se  
www.sepson.com

### Pulling force over the rope length

	Pulling force (tonnes)	Rope speed (m/min)	Total Rope on the drum (m)
1st	10,0	6,0	9,2
2nd	8,8	7,0	19,6
3rd	7,9	7,5	31,3
4th	7,1	8,5	44,1
5th	6,5	9,5	58,2

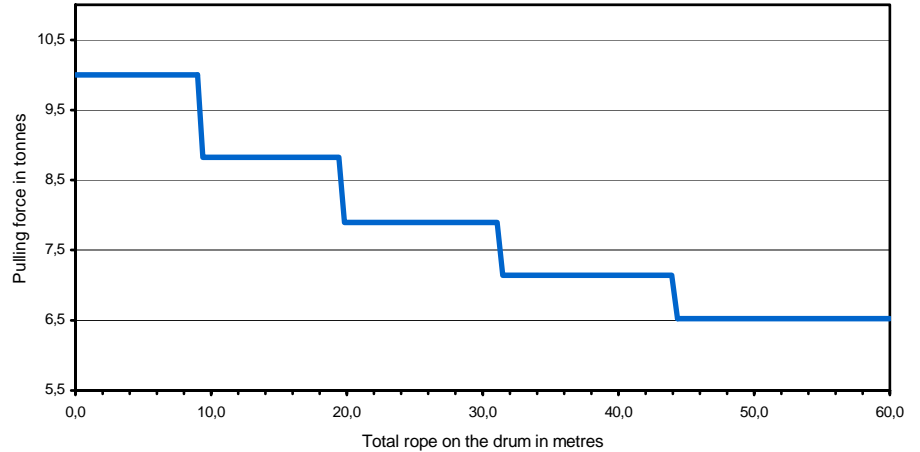

### Mounting instructions

It is always best to seek advice on mounting the winch from both SEPSO and the vehicle manufacturer as early as possible before delivery of the winch.

The winch must be fitted with 12 bolts M14 (hot galvanized) minimum quality 8.8.

Tightening torque 120 Nm (12 kpm) when oiled.

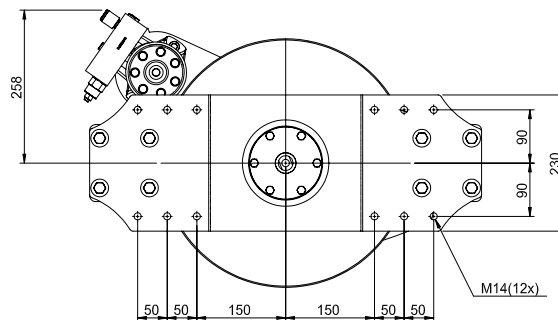

### Hydraulic installation

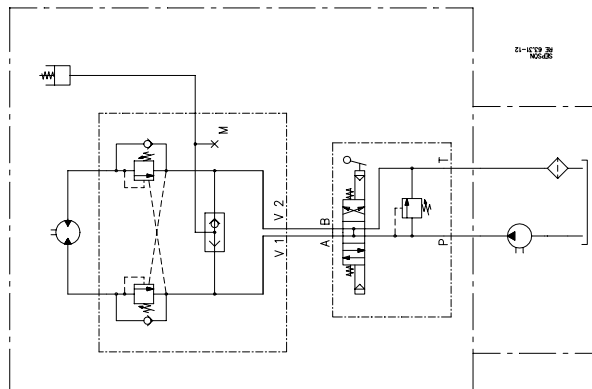

#### Declaration of Conformity

According to the Machine Directive 98/37/EC, Annex IIA

**Sepson AB, P.O. Box 172, SE-780 50 Vansbro, Sweden** declare under our sole responsibility that:

The winch type 63.31 with serial numbers 1010-1962

- are manufactured according to the Machine Directive 98/37/EC
- are manufactured according to following harmonized standards – EN 292-1 and 2

Vansbro December 9, 2005. **Sepson AB** Ulf Jons Designer